

TECHNICAL INFORMATION

MOON OPERATIVE CHAIR

2014
08 25

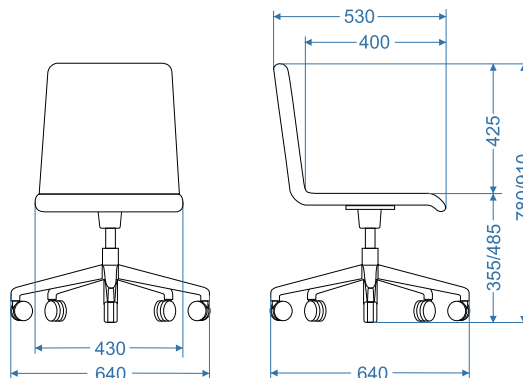

TECHNICAL FEATURES

- Castors:** PA (polyamide) and rubber free wheel castors, diameter 65mm.
- Gas lift:** black or chromed, 130mm run range.
- Bases:** polished aluminum or fiber glass reinforced PA (polyamide) base, metal ring included on plastic version.
- Mechanisms:** pneumatic regulation of the height; Tilt for active dynamic seated posture with stop in working position, knob for tension adjustment.
- Seat:** made from chipboard, covered with foam (density (H5050): 48-51 kg/m³; 170-210 N.). Upholstered with fabric or leather.
- Back:** made from chipboard, covered with foam (density (H5050): 48-51 kg/m³; 170-210 N.). Upholstered with fabric or leather.

PACKING

| Weight NET, kg | Weight, kg | Package type | Unit per box | Volume, m ³ | Units per palette | Boxes per palette | Box dimensions LxWxH (cm) | Pallet dimensions LxWxH (cm) |
|----------------|------------|--------------|--------------|------------------------|-------------------|-------------------|---------------------------|------------------------------|
| 9,32 | 10,82 | assembled | 1 | 0,36 | 4 | 4 | 1400x800x1560 | 680x680x780 |

CHARACTERISTICS

Elegant and universal design chair system, suitable for various office spaces.

Production date: 2013-07-19
Guarantee: 3 years